

Ultra-Precision SMT Resistor (Molded, J-Lead Terminal)

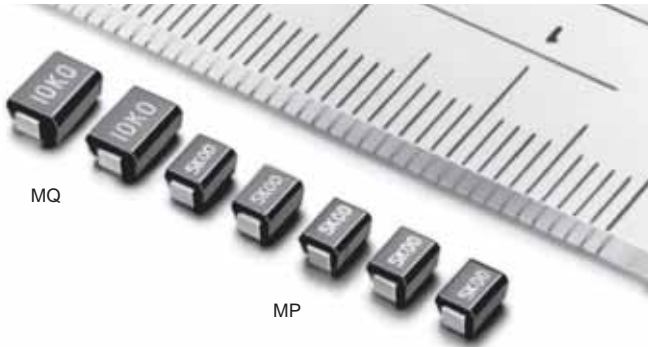

TCR, Resistance Range, Tolerance, Rated Power

Type	TCR (ppm/°C) -55°C to +125°C	Resistance Range (Ω)	Resistance Tolerance (%)	Rated Power (W) at 125°C
MP	0±10	30 to 100	±0.1	0.1
	0±5	100 to 30k	±0.05	
MQ	0±10	30 to 100	±0.1	0.125
	0±5	100 to 60k	±0.05	

Composition of Type Number

Example:

MQ 10K00 L

Tape & Reel Package Required
Resistance Value
Type

Resistance value, in ohm, is expressed by a series of five characters, four of which represent significant digits. The fifth R or K is a dual-purpose letter that designates both the value range (R for ohmic; K for kilo-ohm) and the location of the decimal point.

Configuration

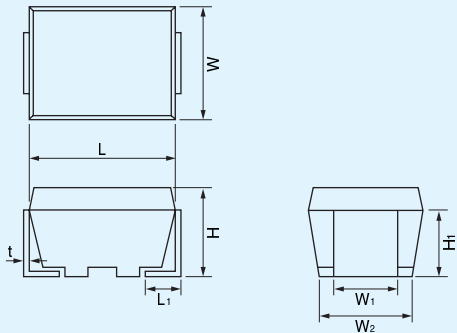

Type	MP	MQ
L	3.2±0.2	4.5±0.2
W	2.5±0.2	3.2±0.2
H	2.0±0.2	
L1	0.6±0.2	0.8±0.2
W1	1.4±0.3	
W2	2.3±0.2	3.0±0.2
H1	1.5±0.3	
t	0.15±0.05	

Dimensions in mm

Power Derating Curve

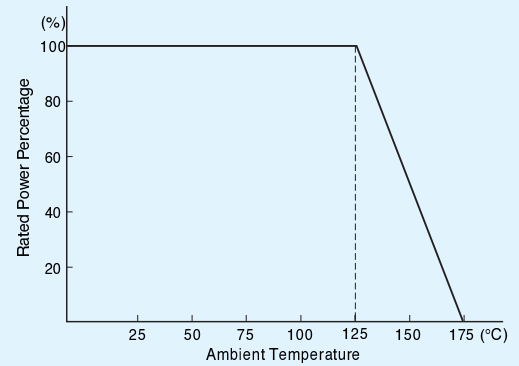

Frequency Characteristics

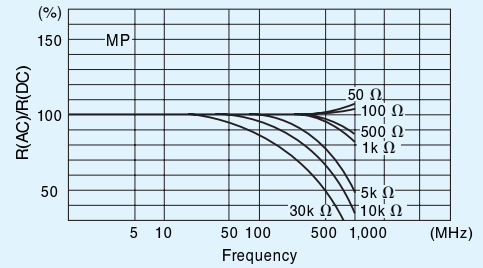

Temperature of Resistor Surface

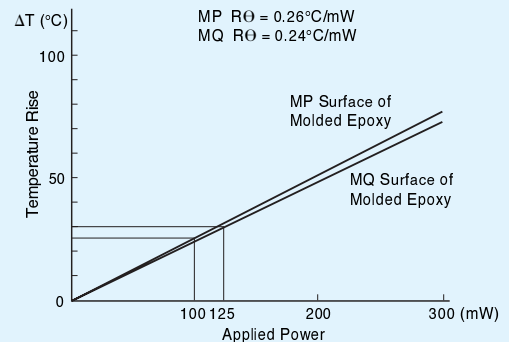

Performance

Parameters	Test Condition	ALPHA Specification	ALPHA Typical Test Data
Maximum Rated Operating Temperature Working Temperature Range Maximum Working Voltage Maximum Working Current		125°C -65°C to +175°C MP=50V, MQ=100V 350 mA	
Thermal Shock Overload	-65°C/30 min. ↔ +175°C/30 min., 5 cycles Rated Voltage x 2.5, 5 sec.	±0.05% ±0.05%	±0.01% ±0.01%
Low Temperature Storage and Operation Substrate Bending Test	-65°C, No Load, 24 hrs. → Rated Voltage, 45 min. Substrate Bent 3mm, 60 sec.	±0.05% ±0.05%	±0.01% ±0.01%
Dielectric Withstanding Voltage Insulation Resistance Resistance to Soldering Heat Moisture Resistance	Atmospheric: AC 200V, 1 min. DC 100V, 1 min. 260°C, 10 sec. +65°C to -10°C, 90% RH to 98% RH, Rated Voltage, 10 cycles (240 hrs.)	±0.01% over 10,000 MΩ ±0.05% ±0.05%	±0.005% over 10,000 MΩ ±0.01% ±0.03%
Shock Vibration, High Frequency	100G, 6ms, Sawtooth Wave, X, Y, Z, each 10 shocks 20G, 10Hz to 2,000Hz to 10Hz, 20 min., X, Y, Z, each 2.5 hrs.	±0.02% ±0.02%	±0.01% ±0.01%
Life	125°C, Rated Power, 1.5 hr. – ON, 0.5 hr. – OFF, 2,000 hrs.	±0.05%	±0.03%
Storage Life	15°C to 35°C, 15% RH to 75% RH, No Load, 10,000 hrs.	±0.005%	±0.0025%
High Temperature Exposure	175°C, No Load, 2,000 hrs.	±0.05%	±0.03%

Tape and Reel Package (based on EIA-481-1)

Tape Dimensions

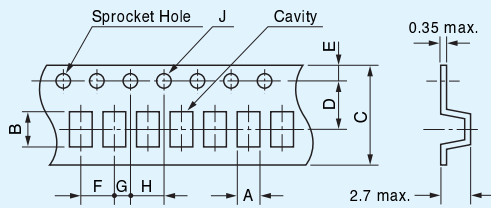

Type	A	B	C	D	E	F	G	H	J
MP	2.8 ±0.2	3.9 ±0.2	12.0 ±0.3	5.5 ±0.05	1.75 ±0.1	4.0 ±0.1	2.0 ±0.05	4.0 ±0.1	φ1.5 +0.1-0
MQ	3.6 ±0.2	5.2 ±0.2	12.0 ±0.3	5.5 ±0.05	1.75 ±0.1	8.0 ±0.1	2.0 ±0.05	4.0 ±0.1	φ1.5 +0.1-0

Dimensions in mm

Reel Dimensions

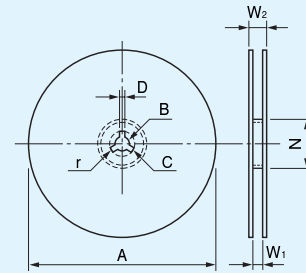

A	N	B	C	D	W1	W2	r
φ178 ±2	φ60 min.	φ13 ±0.5	φ21 ±0.8	2 ±0.5	12.4 +2.0-0	18.4 max.	1.0 ±0.5

Reel Capacity
MP: 1,200 pieces/reel MQ: 800 pieces/reel

Dimensions in mm

Precaution in Using Face-Bonded Chip Resistors

1. Storage

Storage conditions or environment may adversely affect solderability of the exterior terminals. Do not store in high temperature and humidity. The recommended storage environment is lower than 40°C, has less than 70% RH humidity and is free from harmful gases such as sulphur and chlorine.

2. Caution in Soldering

① Hand Soldering

Hand soldering is applicable as shown at right.

Recommended

- Temp. of Iron Tip: 300°C max
- Power of Iron: 20W or less
- Diameter of Tip: dia. 3mm max.

② Solder Reflow in Furnace

Recommended

- Peak Temperature: 245°C
- Holding time: 220°C (40sec.max.)
- To cool gradually at room temperature

③ Dipping in Solder (Wave or Still)

Recommended

- Temp. of Solder: 240°C to 250°C
- Length of Dipping: 3 to 4 seconds
- To cool gradually at room temperature

④ Other

Corrosion-free flux, such as rosin, is recommended.

Do not apply pressure to the molded housing immediately after soldering.

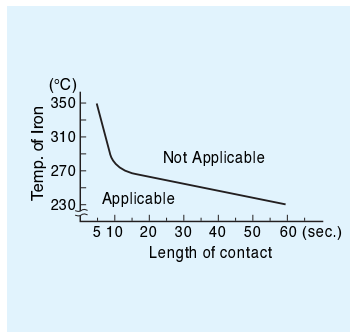

3. Cleaning

Use volatile cleaner such as methylalcohol or propylalcohol.

4. Circuit Board Design

The dimensions of solder land must be determined in conformity with the size of resistors and with the soldering method. They are also subject to the mounting machine and the material of the substrate. See example below.

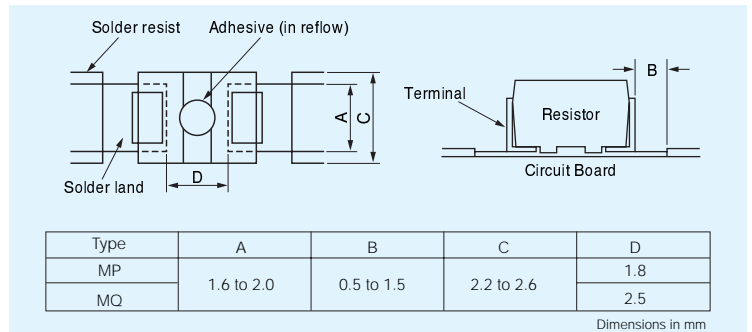

Dimensions in mm

When parts are mounted on a board in high density, solder can possibly attach to the resistors in an excessive amount to affect performance or reliability of the resistors. To prevent this effect, the use of solder resist is recommended to isolate solder lands.